

User Manual

MODULE GAS GRILL X/Y
NG

EN

RÖSHULTS



IT IS IMPERATIVE THAT YOU READ THIS MANUAL BEFORE USING THE GRILL. FOR OUTDOOR USE ONLY.

⚠ DANGER!

If you smell gas

- **Shut off gas to the appliance.**
- **Extinguish any open flame.**
- **Open lid.**
- **If odor continues, keep away from the appliance and immediately call your gas supplier or your fire department.**

Failure to follow these instruction could result in fire , explosion or burn hazard which could cause property damage ,personal injury or death.

⚠ WARNING!

- **Do not store or use gasoline or other flammable liquids or vapors in the vicinity of this or any other appliance.**
- **A propane cylinder not connected for use shall not be stored in the vicinity of this or any other appliance.**

⚠ WARNING!

- Never operate this appliance unattended .
- If a fire should occur , keep away from the appliance and immediately call your fire department . Do not attempt to extinguish and oil or a grease fire with water.
- **THIS INSTRUCTION MANUAL CONTAIN IMPORTANT INFORMATION NECESSARY FOR THE PROPER ASSEMBLY AND SAFE USE OF THE APPLIANCE**
- **READ AND FOLLOW ALL WARNINGS AND INSTRUCTIONS BEFORE ASSEMBLING AND USING THE APPLIANCE**
- **KEEP THIS MANUAL FOR FUTURE REFERENCE**

Precautions

⚠ Warning!

- Do not try lighting this appliance without reading the "LIGHTING INSTRUCTIONS" section of this manual.

TESTED IN ACCORDANCE WITH ANSI Z21.89-2017· CSA 1.18-2017 STANDARD FOR OUTDOOR COOKING GAS APPLIANCES. THIS GRILL IS FOR OUTDOOR USE ONLY.

Check your local building codes for the proper method of installation. in the absence of local codes, with either the National Fuel Gas Code, ANSI Z223.1/NFPA 54, Storage and Handling of liquefied Petroleum,ANSI/NFPA58; or the Natural Gas and Propane Installation Code, CSA B149.1, or the Propane Storage and Handling Code, CSA B149.2 this unit should be installed in accordance with the National Fuel Gas Code No. Z223.1-1988 and the National Electrical Code ANSI/NFPA No. 70-1990. CSA B1491.1,or the Propane Storage and Handling Code, CSA B149.2.

This outdoor cooking gas appliance is not intended to be installed in or on boats. This appliance is not intended to be installed in or recreational vehicles.

Keep the fuel supply hose away from any heated surface.

California proposition 65-warning

The burning of gas fuel generates some byproducts, which are on the list of substances which are known by the State of California to cause cancer or reproductive harm. California law requires businesses to warn customers of potential exposure to such substances. To minimize exposure to these substances, always operate this unit according to the use and care manual, ensuring you provide good ventilation when cooking with gas.

- The use of alcohol, prescription, or non-prescription drugs may impair the consumer's ability to properly assembly or safety operation the appliance
- When cooking with oil or grease, have a type BC or ABC fire extinguisher readily available
- In the event of an oil or grease fire do not attempt to extinguish with water, Immediately call the fire department. A Type BC or ABC fire extinguisher may, in some circumstances contain the fire.
- In the event of rain, snow, hail sleet, or other forms of precipitation while cooking with oil or grease, cover the cooking vessel immediately and turn off the appliance burners and gas supply. Do note attempt to move the appliance or cooking vessel.
- Keep children and pets away from the appliance at all times.
- Do not move the appliance when in use .
- This appliance is not intended for and should never be used as a heater.

Safety practices to avoid personal injury

When properly cared for, your Röshults Grill will give safe, reliable service for many years. However, extreme care must be used since the grill produces intense heat and that can increase accident potential. When using this appliance, basic safety practices must be followed, including the following:

- Read this Care and User Manual carefully and completely before using your grill to reduce the risk of fire, burn hazard or other injury.
- Do not repair or replace any part of the grill unless specifically recommended in this manual. All other service should be referred to a qualified technician

CHILDREN SHOULD NOT BE LEFT ALONE OR UNATTENDED IN AN AREA WHERE THE GRILL IS BEING USED. NEVER ALLOW THEM TO SIT, STAND OR PLAY ON OR AROUND THE GRILL AT ANY TIME.

DO NOT STORE ITEMS OF INTEREST TO CHILDREN AROUND OR BELOW THE GRILL OR IN THE SIDEBOARD. NEVER ALLOW CHILDREN TO CRAWL INSIDE OF THE GRILL OR SIDEBOARD.

Never let clothing, pot holders or other flammable materials come in contact with or get too close to any grate, burner or hot surface until it has cooled. Fabric may ignite and result in personal injury.

For personal safety, wear proper apparel. Loose fitting garments or sleeves should never be worn while using this appliance. Some synthetic fabrics are highly flammable and should not be worn while cooking. Only certain types of glass, heat-proof glass ceramic, earthenware, or other glazed utensils are suitable for grill use. These types of materials may break with sudden temperature changes. Use only on low or medium heat settings according to the manufacturer's directions. Do not heat unopened food containers as a build-up of pressure may cause the container to burst. Use a covered hand when opening the grill lid. Never lean over an open grill.

WHEN LIGHTING A BURNER, ALWAYS PAY CLOSE ATTENTION TO WHAT YOU ARE DOING. BE CERTAIN YOU ARE TURNING THE IGNITER LABELED FOR THE BURNER YOU INTEND ON USING.

DO NOT OPERATE BURNERS ON HIGH WITH LID CLOSED.

Precautions

⚠ Warning!

Never cover slots, holes or passage in the oven bottom or cover an entire rack with material such as aluminum foil. Doing so block air flow through the oven and may cause carbon monoxide poisoning. Aluminum foil lining may trap heat causing a fire hazard.

When using the grill, do not touch the grill rack, burner grate or immediate surroundings as these areas become extremely hot and could cause burns. Use only dry potholders. Moist or damp potholders on hot surfaces may cause burns from steam. Do not use a towel or bulky cloth in place or potholders. Do not let potholders touch hot portions of the grill rack.

Grease is flammable. Let hot grease cool before attempting to handle it. Avoid letting excess grease deposits collect in the grease tray at the bottom of the grill's firebox. Clean often.

Aluminum foil lining may trap heat causing a fire hazard.

For proper lighting and performance of the burners keep the burner ports clean. It is necessary to clean them periodically for optimum performance (see section Care & Maintenance). The burners will only operate in one position and must be mounted correctly for safe operation.

Clean the grill with caution. Avoid steam burns; do not use a wet sponge or cloth to clean the grill while it is hot. Some cleaners produce noxious fumes or can ignite if applied to a hot surface.

INSECT WARNING!

SPIDERS AND INSECTS CAN NEST IN THE BURNERS OF THIS AND ANY OTHER GRILL, AND CAUSE THE GAS TO FLOW IMPROPERLY. THIS IS A VERY DANGEROUS CONDITION WHICH CAN CAUSE A FIRE TO OCCUR BEHIND THE VALVE PANEL, THEREBY DAMAGING THE GRILL AND MAKING IT UNSAFE TO OPERATE.

INSPECT THE GRILL TWICE A YEAR.

Be sure all grill controls are turned off and the grill is cool before using any type of aerosol cleaner on or around the grill. The chemical that produces the spraying action could, in the presence of heat, ignite or cause metal parts to corrode. Do not use the grill for cooking excessively fatty meats or products which promote flare-ups. Do not operate the grill under unprotected combustible construction. Use only in well ventilated areas. Do not use in buildings, garages, sheds, breezeways or other such enclosed areas.

THIS UNIT IS FOR OUTDOOR USE ONLY

Keep the area surrounding the grill free from combustible materials, trash, or combustible fluids and vapors such as gasoline or charcoal lighter fluid.

Do not obstruct the flow of combustion and ventilation air. If the unit is stored indoors ensure that it is cool. If propane is used, the cylinder must be unhooked and the propane cylinder stored outside in a well-ventilated area, out of the reach of children.

DO NOT USE BRIQUETTES OF ANY KIND IN THE GRILL

The Röshults Grill is designed for optimum performance without the use of briquettes. Do not place briquettes on the radiant as this will block off the area for the grill burners to vent. Adding briquettes can damage ignition components and knobs, and void the warranty.

Never use the grill in extremely windy conditions. If located in a consistently windy area (oceanfront, mountaintop, etc.) a windbreak will be required. Always adhere to the specified clearance.

Placement of the grill

Clearance

To Non-Combustible Construction

A minimum of 3" clearance from the back of the grill to non-combustible construction is required for the lid to open fully. The outdoor cooking gas appliance shall not be used under overhead combustible construction.

DO NOT INSTALL THIS UNIT INTO COMBUSTIBLE ENCLOSURES

Location

When determining a suitable location take into account concerns such as exposure to wind, proximity to traffic paths and keeping any gas supply lines as short as possible. Locate the grill only in a well-ventilated area. Never locate the grill in a building, garage, breezeway, shed or other such enclosed areas without an approved ventilation system. During heavy use, the grill will produce a lot of smoke. Lock the wheels (if used) after the grill is placed in a suitable position.

Gas hook-up

Only the hose assembly supplied with the grill should be used. Any replacement hose assembly must be specified by the grill manufacturer.

This is a Natural gas configured grill. Do not attempt to use a liquid propane supply for the grill.

Total gas consumption (per hour) of The BBQ Grill Gas Module X with all burners on "HIGH":

Main burners	13,000 Btu/hr.
Total	26,000 Btu/hr.

The installation of this appliance must conform with local codes or, in the absence of local codes, with the national fuel gas code, ANSI Z223.1a-1988. Installation in Canada must be in accordance with the Standard Can1-b149.1 and/or .2 (installation code for gas burning appliances and equipment) and local codes.

Requirements NG, Natural Gas

Connection:

Your gas grill is equipped with gas supply orifices for use only with Natural gas. It is also equipped with a high capacity hose for connection to Natural gas supply from home.

To connect the natural gas, always follow instructions from the Natural gas supplier.

1. Follow instructions from NG supplier.
2. Check quick release connector on Natural gas hose and supply the tube from home.
3. Make sure all burner valves are in their off position.
4. Inspect valve connections, port and Natural gas assembly. Look for any damage or debris. Remove any debris. Inspect hose for damage. Never attempt to use damaged or obstructed equipment.

5. When connecting Natural gas hose to the supply from home, do not use a wrench to tighten. Use of a wrench may damage the quick coupling nut and result in a hazard.
6. Use a soapy water solution to check all connections for leaks before attempting to light the grill, see below. If a leak is found, turn off and do not use the grill until a local gas dealer can make repairs.

Installation of Natural gas

The qualified service agency is responsible for the proper installation of this kit. The installation is not proper and complete until the operation of the converted appliance is checked as specified in the manufacturer's instructions supplied with the kit.

Step 1: Using an adjustable wrench to hold the gas manifold connection secure, use a 3/4" wrench. Assemble the natural gas 10' hose that comes with the grill. Tighten the connection carefully using two wrenches.

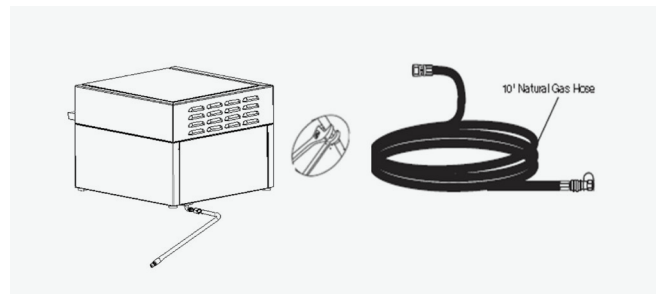

Step 2: Connect the Natural gas hose to the Natural gas supply from home.

⚠ Warning!

Ensure "quick release connector" is fully connected onto Natural gas hose.

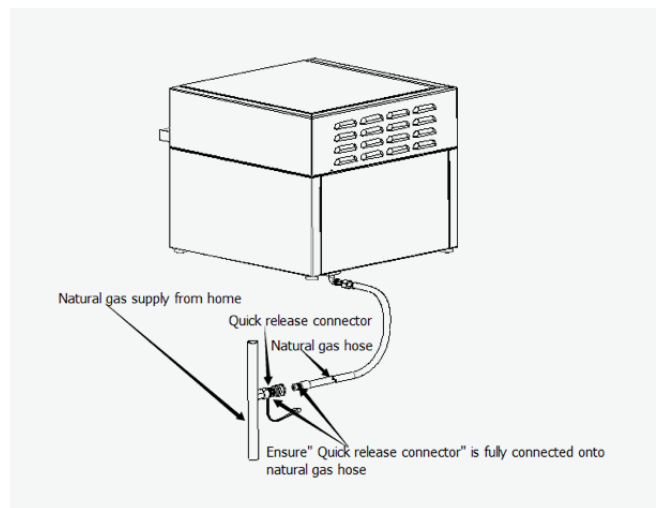

Leak testing

General

Although all gas connections on the grill are leak tested at the factory prior to shipment, a complete gas tightness check must be performed at the installation site due to possible mishandling in shipment, or excessive pressure unknowingly being applied to the unit. Periodically check the whole system for leaks following the procedures listed below. If the smell of gas is detected at anytime you should immediately check the entire system for leaks.

Before testing:

The outdoor cooking gas appliance and its individual shut-off valve must be disconnected from the gas supply piping system during any pressure testing of that system at test pressures in excess of 0.5 psi (3.5 kPa).

Make sure that all packing material is removed from the grill including the burner tie-down straps. Please remove the 'Fire Tested' label from the rear burner before use. All burners in your new Röshults grill have been fire tested at the factory. You may notice a slight discoloration due to the factory fire testing.

DO NOT SMOKE WHILE LEAK TESTING.

NEVER LEAK TEST WITH AN OPEN FLAME.

Make a soap solution of one part liquid detergent and one part water. You will need a spray bottle, brush, or rag to apply the solution to the fittings.

To test

Make sure all control valves are in the "OFF" position. Turn the gas supply on. Check all connections from the gas supply up to and including the connection to the manifold pipe assembly (the pipe that goes to the burners).

Apply a soapy water mixture to the following:

- A. Natural gas supply from home.
- B. The inlet end of the corrugated pipe is connected to the gas valve, and the other end is connected with L type connector.
- C. Gas valve.
- D. The corrugated pipe outlet is connected to the gas valve.
- E. The corrugated pipe outlet is aligned to the burner hole.
- F. L type connector.
- G. Ng, Natural gas hose.

Soap bubbles will appear where a leak is present. If a leak is present, immediately turn off the gas supply, tighten any leaking fittings, turn gas on, and recheck.

Should the gas continue to leak from any or all of the fittings, turn off the gas supply, and contact our customer service at +46 36 440 32 10.

Only those parts recommended by the manufacturer should be used on the grill. Substitution will void the warranty. Do not use the grill until all connections have been checked and do not leak.

Gas flow check:

Each grill burner is tested and adjusted at the factory prior to shipment; however, variations in the local gas supply may make it necessary to adjust the burners. The flames of the burners should be visually checked.

Flames should be blue and stable with no yellow tips, excessive noise or lifting. If any of these conditions exist, check to see if the air shutter or burner ports are blocked by dirt, debris, spider webs, etc. If you have any questions regarding flame stability, please call customer service +46 36 440 32 10.

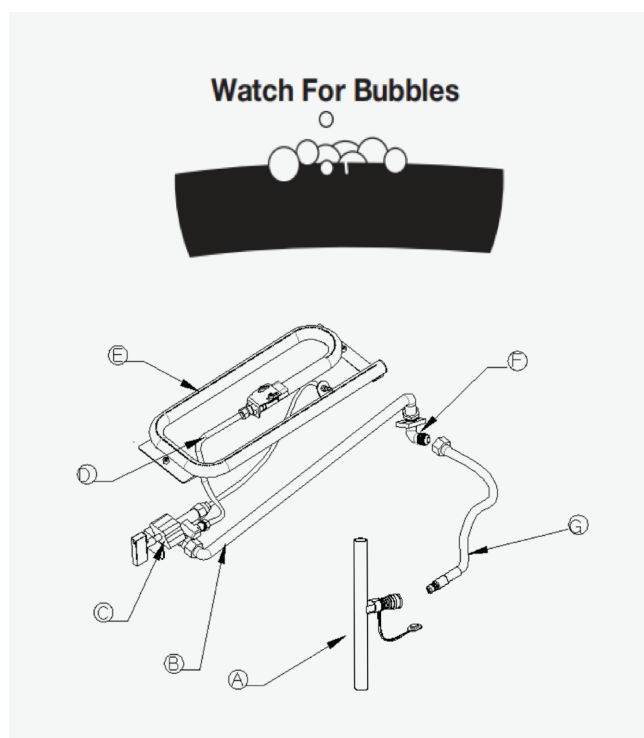

Installer final checklist

- Specified clearance maintained 24" from combustibles.
- All internal packaging removed. Knobs turn freely.
- Burners are tight and sitting properly on orifices.
- Natural gas hose connected.
- Unit tested and free of leaks User informed of gas supply shut off valve location.
- Battery is mounted in batterybox.
(see p.11 "changing the battery")

User, please retain these instructions for future reference.

Operating instructions

General use of the grill

Each main burner is rated at 13,000 Btu/hr. The main grill burners encompass the entire cooking area and are side ported to minimize blockage from falling grease and debris.

Above the burners are stainless steel radiant (flame tamer). The igniter knobs are located on the lower center portion of the valve panel. Each rotary igniter is labeled on the control panel.

Using the grill:

Grilling requires high heat for searing and proper browning. However, when grilling large pieces of meat or poultry, it may be necessary to turn the heat to a lower setting after the initial browning. This cooks the food through without burning the outside.

Food cooked for a long time or food basted with a sugary marinade may need a lower heat setting near the end of the cooking time.

To begin:

Make sure the grill has been leak tested and is properly located.

1. Remove any remaining packing material.
2. Light the grill burners using the instructions in this manual see page 7.
3. Push and Turn the control knob(s) and preheat the grill for 5 minutes. The grill lid is to be closed during the appliance preheat period.
4. Place the food on the grill and cook to the desired doneness. Adjust heat setting, if necessary. The control knob may be set to any position between "  ".

Note: The grill is designed to grill efficiently without the use of lava rocks or briquettes of any kind. Heat is radiated by the stainless-steel flame tamers positioned above each burner.

Note: The hot grill sears the food, sealing in the juices. The longer the preheat, the faster the meat browns and the darker the grill marks.

DO NOT LEAVE THE GRILL UNATTENDED WHILE COOKING.

Lighting instructions

⚠ Warning! Important!

Before lighting

Inspect the gas supply hose prior to turning the gas "ON". If there is evidence of cuts, wear, or abrasion, it must be replaced prior to use. Only the manufacturer's supplied replacement should be used.

Do not use the grill if the odor of gas is present. Only hose assembly supplied with the unit should be used. Never substitute hose for those supplied with the grill. If a replacement is necessary, contact the factory for proper replacement.

Screw the NG hose onto the tank. Leak check the hose and connections with a soap and water solution before operating the grill (see assembly instruction).

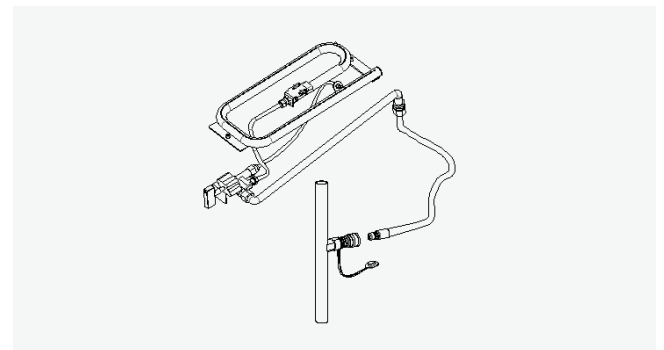

To light the grill burner

Always keep your face and body as far from the grill as possible when lighting. Your Röshults grill has a built-in ignition. The igniter is built in to the valve. To ignite each burner simply push and turn the control Knobs to the "HIGH" setting, you will hear the valve click as it sends a spark to the pilot flame. If the burner does not light, wait 5 minutes for any excess gas to dissipate and then retry.

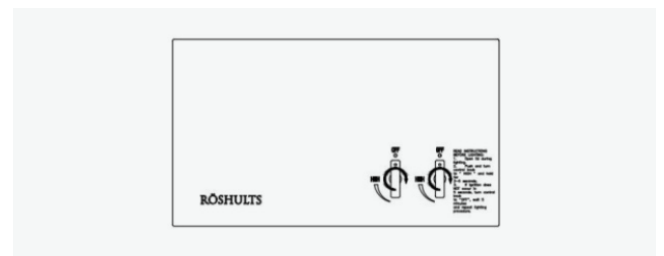

Lighting the main burner

1. Read all instructions before lighting.
2. Open lid during lighting.
3. Push and turn the main burner knob slowly to "HIGH".
4. If ignition does not occur in 5 seconds, turn the knob(s) off, wait 5 minutes, then repeat the lighting procedure or light by match.
5. To turn burners off, turn the control knob clockwise until it locks in the OFF position. Turn gas supply to "OFF".

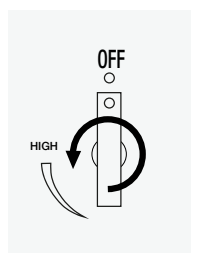

To match light the grill:

If the burner will not light after several attempts then the burner can be match lit. If you've just attempted to light the burner with the igniter, allow 5 minutes for any accumulated gas to dissipate. Keep your face and hands as far away from the grill as possible. Insert a lit extended match or lighter through the cooking grids to the burner.

Press the control knob and rotate left to the light setting, continue to press the knob until the burner ignites. Burner should light immediately. If the burner does not light in 4 seconds turn the knob off, wait 5 minutes and try again.

Lighting using match light extension rod

1. Turn OFF all burner valves.
2. Make sure the lid is open
3. Place a lighted match between the coils on the extension rod and hold next to the burner.
4. Turn the control knob(s) to the "HIGH/light" position, Burner should light immediately.
5. If the burner does not light in 4 seconds, turn the knob off, wait 5 minutes and repeat above procedures.

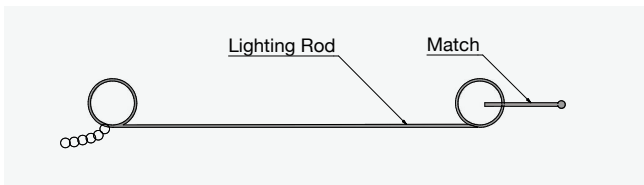
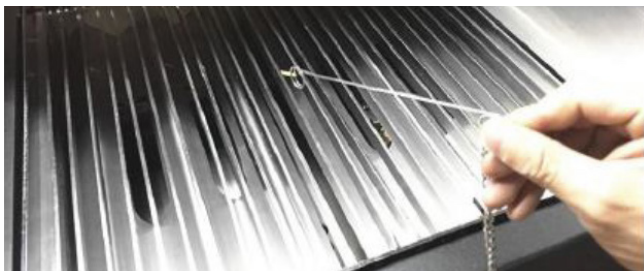

⚠ Danger!

Keep your face and hands as far away from the grill as possible when lighting it.

Flame Characteristics

This procedure outlines how to check for the proper burner flame characteristics. Check for proper burner flame characteristics. Each burner is adjusted prior to shipment; however, variations in the local gas supply may take minor adjustments necessary.

Burner flames should be blue and stable with no yellow tips, excessive noise, or lifting. If any of these conditions exist call our customer service line. If the flame is yellow, it indicates insufficient air. If the flame is noisy and tends to lift away from the burner, it indicates too much air.

Visually check the burner flames prior to each use. The flame should look like this picture. If they do not, refer to the burner maintenance part of this manual.

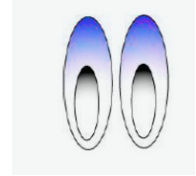

⚠ Warning!

FIRE, EXPLOSION, AND CARBON-MONOXIDE HAZARD IF THE INFORMATION IN THESE INSTRUCTIONS IS NOT FOLLOWED EXACTLY, A FIRE, EXPLOSION, OR PRODUCTION OF CARBON MONOXIDE MAY RESULT CAUSING PROPERTY DAMAGE, PERSONAL INJURY, OR LOSS OF LIFE.

Module Gas Grill NG

Parts

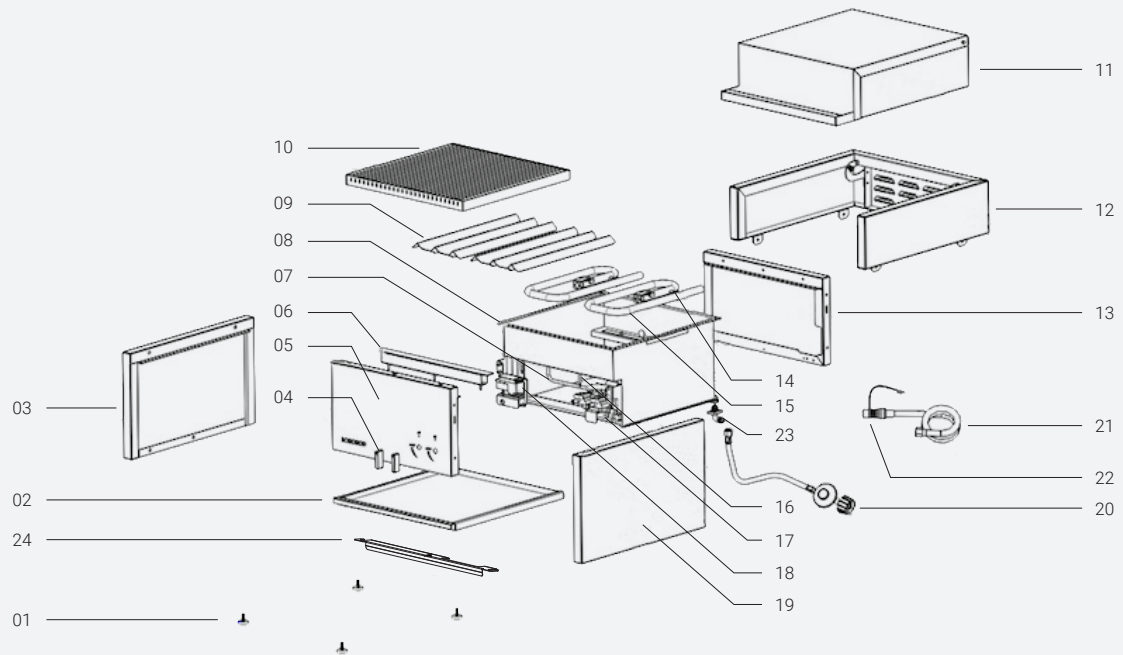

NO	DESCRIPTION	Q'TY
01	Feet support	4
02	Drip tray	1
03	Left panel	1
04	Knob	2
05	Front panel	1
06	Decorative plate	1
07	Corrugated pipe	2
08	Oven body	1
09	Fireproof plate	2
10	Grill	1
11	Upper lid	1
12	Lid base	1

NO	DESCRIPTION	Q'TY
13	Oven rear board	1
14	Thermocouple	2
15	Burner	2
16	Ignition needle	2
17	Air valve	2
18	Igniter	1
19	Right plate	1
20	Propane gas hose assembly	1
21	NG hose assembly	1
22	NG quick coupling	1
23	L type connector	1
24	Hose Shield Assy	1

Care & maintenance

Before starting cleaning the grill, keep it in an area clear and free from combustible materials, gasoline and other flammable vapors and liquids. Do not obstructing the flow of combustion and ventilation air.

Storage

Your gas cylinder must be stored outdoors in a well ventilated area and must be disconnected from your gas grill when not in use. Ensure that you are outdoors and away from any sources of ignition before attempting to disconnect your gas cylinder from your gas grill. When you are using your gas grill after a period of storage, please ensure to check for gas leaks and check for any obstructions in the burner etc. before using. Always follow the cleaning instructions to ensure gas grill is safe. If gas grill is stored outdoors ensure to check that all areas under the front panel are free from any obstructions (dirt, insects etc.) as this may affect the flow of gas.

- Store your barbecue in a cool dry place. It may be necessary to dry the barbecue and the inside of the cover if used.
- Clean the grill grate by using a brush or ruff sponge, soap and lukewarm water. Wrap the burners in aluminum foil to help prevent insects or other debris from obstructing the burners.

Maintenance

- Maintenance is recommended every 90 days for your gas grill, but it is absolutely necessary to perform maintenance at least once a year. By doing so, you will extend the life of your gas grill. Your gas grill is easy to clean with minimum effort, just follow these helpful hints for cleaning convenience.

Stainless steel

The grill is made of stainless steel. There are many different stainless steel cleaners available. Always use the mildest cleaning procedure first, scrubbing in the direction of the grain. To touch up noticeable scratches in the stainless steel, sand very lightly with dry 100 grit emery paper in the direction of the grain. Specks of grease can gather on the surfaces of the stainless steel and bake on to the surface and give the appearance of rust. For removal use an abrasive pad in conjunction with a stainless steel cleaner.

Main cooking grill grates

The easiest way to clean the grill is immediately after cooking is completed and after turning off the flame. Wear a barbecue mitt to protect your hand from the heat and steam. Dip a stainless steel bristle barbecue brush in tap water and scrub the hot grill. Dip the brush frequently in the bowl of water. Steam, created as water contacts the hot grill, assists the cleaning process by softening any food particles. The food particles will fall and burn. If the grill is allowed to cool before cleaning, cleaning will be more difficult.

It is also possible to keep the grill grates clean by turning the burner knob to maximum and burning off the fat and grease for five minutes after cooking. Use a stainless steel bristle brush to remove any particularly stubborn dirt.

ENSURE THAT THE GAS SUPPLY AND THE KNOBS ARE IN THE "OFF" POSITION. MAKE SURE THE RANGE TOP BURNER IS COOL BEFORE REMOVAL.

Grill burners

Extreme care should be taken when moving a burner as it must be correctly centered on the orifice before any attempt is made to relight the grill. Frequency of cleaning will depend on how often you use the grill.

Grill burner cleaning

Ensure the gas supply is off and the knobs are in the "OFF" position. Make sure the grill is cool. Clean the exterior of the burner with a wire brush. Clear stubborn scale with a metal scraper. Clear any clogged ports with a straightened paper clip. Never use a wooden toothpick as it may break off and clog the port. Please note if insects or other obstructions are blocking the flow of gas through the burner or nozzle, and if so, you will need to call our customer service line.

- Clean the burners as described above after each barbecue - residual marinades and fat/grease can cause damage to the metal parts of the grill.
- The burner holes can be cleaned with a pipe cleaner or similar.

Grease tray cleaning

The grease tray should be emptied and wiped down periodically and washed in a mild detergent and warm water solution. A small amount of sand or cat litter may be placed in bottom of grease tray to absorb the grease. Check the grease tray frequently, don't allow excess grease to accumulate and overflow out of the grease tray.

Stainless steel cleaning

- The grill is made from stainless steel. Some parts of the frame, depending on the model, can be powder coated on top of stainless steel material.
- The easiest way to keep your BBQ in a good condition we recommend cleaning the grill after each use.
- Use lukewarm water, soap and a sponge. Always scrub in the direction of the grain.

Outside/frame of the grill

- Wipe down the outside of the grill to ensure that there is no residual marinade or fat/grease that could corrode the surface. Use soap and water to remove any stubborn residues.
- For cleaning powder coated surface, use a cloth or a soft sponge and lukewarm water.

Hose

- Rubber has a limited useful life and becomes worn over time. If there is any damage or cracks, replace the hose immediately.

Stainless Drip Cover in bottom of the grill frame

How to clean and remove the bottom plate:

1. Remove the grill grate and fire proof plate.

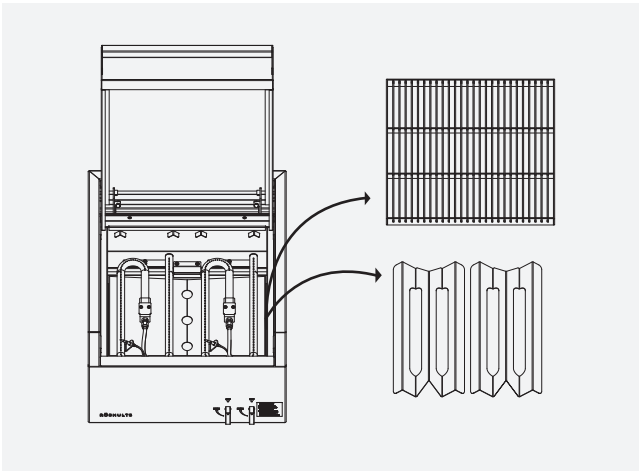

2. Pull out the drip tray.

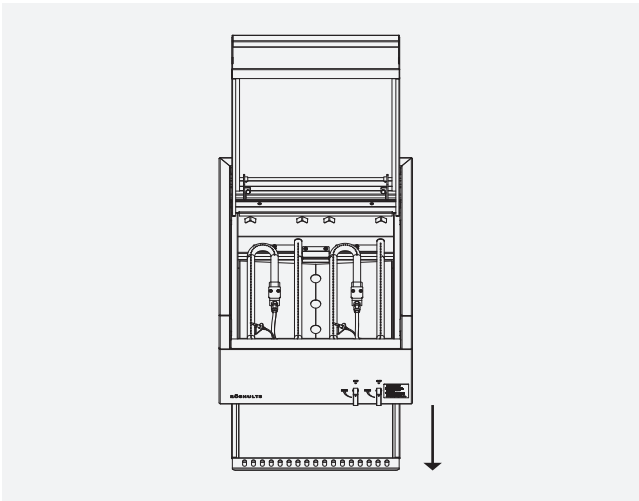

3. Lift the bottom drip cover by putting a finger through the hole closest to the back of the grill and lift upwards and then pull outwards.

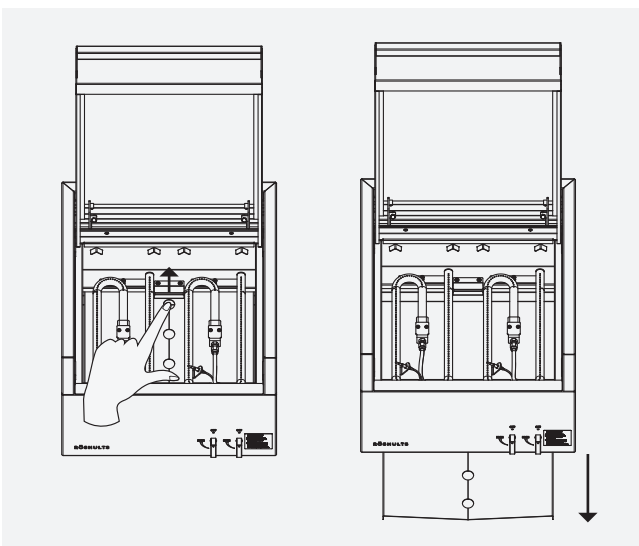

Reassemble the grill in reverse order to the way you disassembled.

Grill part

- Use a plastic or wooden scraper to scrape away grease/fat from the inside of the grill. Soapy water and a sponge is recommended for more thorough cleaning. It is important to ensure that the regulator and valves do not become wet.
- It is important to keep the inside of the grill clean - otherwise there is a risk that residual fat and grease will ignite.

Drip tray

- Check the sand in the drip tray regularly to ensure that it is dry and clean. Change the sand as required (use fine-grain sand or cat litter box sand)

Changing the battery

The barbecue is equipped with electrical ignition and is powered with an AA battery. After a while, the battery needs to be changed. The battery holder is placed on in the front on the left side under the grill. You change the battery by twisting the lower section of the battery holder counter-clockwise. Remove the old battery and replace it with a new one. Remount the battery holder and check that it works.

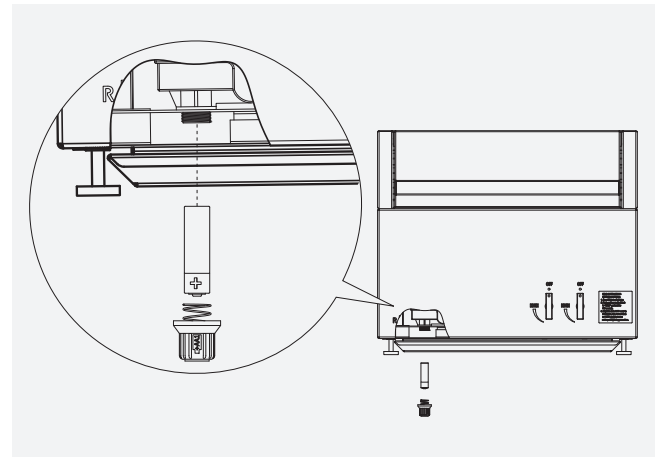

Troubleshooting

Spider and insect warning!

Spiders and insects can nest in the burners of this or any other grill, and cause the gas to flow from the front of the burner. This is a very dangerous condition which can cause a fire to occur behind the valve panel, thereby damaging the grill and making it unsafe to operate.

When to look for spiders

You should inspect the burners at least once a year or immediately after any of the following conditions occur:

- The smell of gas in conjunction with the burner flames appearing yellow.
- The grill does not reach temperature.
- The grill heats unevenly.
- The burners make popping noises.

Before calling for service

If the grill does not function properly, use the following checklist before contacting your dealer for service.

FAQ

Q: What is the function of the plates that rest above the burners?

A: These plates, or flame fenders as they are also known, provide protection against flames that flare up towards the food on the grill grates. The plates significantly increase the useful life of the burners by protecting them against oil, fat, grease and juices from the food. The plates also provide a very even distribution of heat at the grill grates.

Q: How long do I need to wait before I can start cooking food on the grill?

A: It normally takes 5-10 minutes for the grill to reach the right temperature.

Q. Can I use lava stones in the grill?

A: No, lava stones should not be used with Röshults' grills.

Problems

Grill won't light when the control knob is rotated.

Solutions

- Check the gas supply.
- Clean wire(s) and/or electrode by rubbing with alcohol and clean swab. Wipe with dry cloth.
- Make sure the wire is connected to electrode assembly.
- Do other burners on the unit operate?
- Check to see if other burners operate. If so, check the gas orifice on the malfunctioning burner for an obstruction.

Burner flame is yellow or orange, in conjunction with the odor of gas.

- Call our customer service line +46 36 440 32 10..

Low heat with knob in "HIGH" Position.

- Is the fuel hose bent or kinked?
- Is the grill in a dusty area?
- Is there adequate gas supply available?
- If it is only one burner that appears low, does the orifice or burner need cleaning?
- Is the gas supply, or gas pressure low?
- Is the grill being preheated for 15 minutes?

Warranty

Model: Module Gas Grill 50
Stainless Steel Outdoor Gas Grill

Röshults warrants to the original consumer purchaser of each Outdoor Gas Grill that when subject to normal residential use, it is free from defects in workmanship and materials for the periods specified below. This warranty excludes grills used in rental or commercial applications. There will be a shipping and handling charge for the delivery of the warranty part(s).

COMPONENT	WARRANTY PERIOD
Burners	5 years
Stainless Steel Flame Tamer	3 years
Stainless Steel Cooking Grids	3 years
Valves	1 year
Frame, Housing, Cart, Control Panel, Igniter, and Related Parts	1 year
All Stainless Steel Parts	3 years

Our obligation under this warranty is limited to repair or replacement, at our option, of the product during the warranty period. The extent of any liability of Röshults under this warranty is limited to repair or replacement.

This warranty does not cover normal wear of parts, damage resulting from any of the following:

- Negligent use or misuse of the product.
- Use on improper fuel/gas supply.
- Use contrary to operating instructions.
- Alteration by any person other than our factory service center.

The warranty period is not extended by such repair or replacement.

Warranty claim procedure

If you require service or parts for your grill, please contact our Warranty Service Center for factory direct assistance. Our hours of operation are 8 AM to 5 PM CET.

Our phone number: +46 36 440 32 10

Our email: info@roshults.com

Please direct all correspondence to your local dealer.

Product repair as provided under this warranty is your exclusive remedy. Röshults shall not be liable for any incidental or consequential damages for breach of any express or implied warranty on its products. Except to the extent prohibited by applicable law, any implied warranty or merchantability or fitness for a particular purpose on this product to the duration of the above warranty. Some states do not allow the exclusion or limitation of incidental or consequential damages, or allow limitations on how long an implied warranty lasts, so the above limitations or exclusions may not apply to you. This warranty gives you specific legal rights, and you may have other rights, which vary from state to state.



Module Gas Grill US

Design:	Broberg & Ridderstråle
Art no:	200425 / 200426, NG (Adapted for US market)
Colours:	Anthracite / Brushed Stainless Steel
Materials:	Stainless Steel
Measurements:	L 500 D 570 H 431 mm / L 19.7 D 22.4 H 17 in
Weight:	38 kg / 84 lb
Total heat input:	26 000 Btu

Color & Sample

Frame available in

- Anthracite. Akzo Nobel**
 Röshults Sample: CO004
- Brushed Stainless Steel. 316L**
 Röshults Sample: ME003

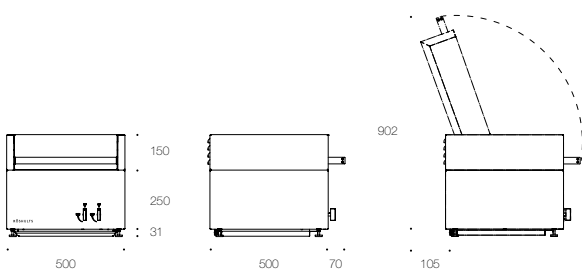

BBQ GRILL GAS MODULE (MM)

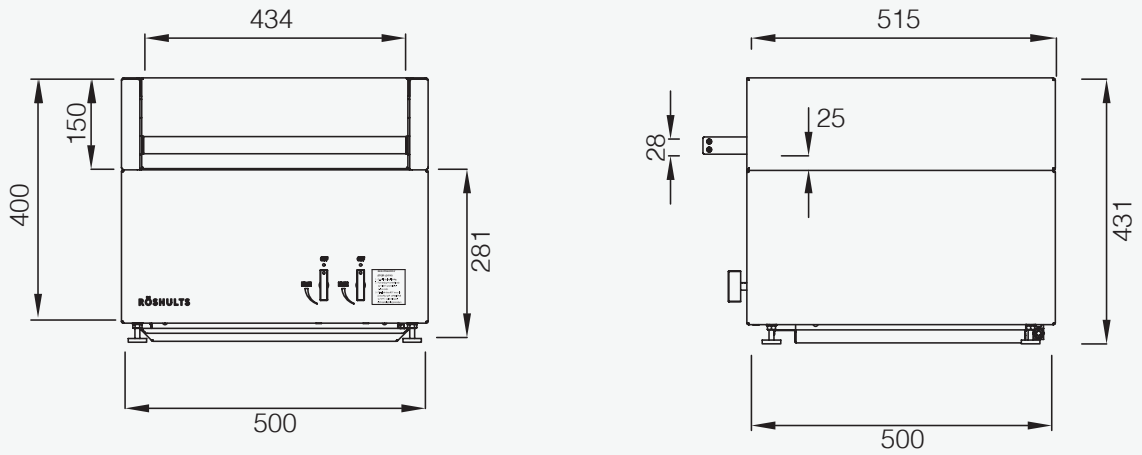

BBQ GRILL GAS MODULE (IN)

