

User Manual

MODULE GAS GRILL 50



RÖSHULTS



Module Gas Grill 50

Design:	Broberg & Ridderstråle
Art no:	200360 / 200361 EU market
Colours:	Anthracite / Brushed Stainless Steel
Materials:	Stainless Steel
Measurements:	L 500 D 570 H 431 mm / L 19.7 D 22.4 H 17 in
Weight:	38 kg / 84 lb
Gas Category:	28 - 30 mbar, 50 mbar, 37 mbar, 20 mbar NG
Marketing label	CE

Color & Sample

Frame available in



Anthracite. Akzo Nobel

Röshults Sample: CO004



Brushed Stainless Steel. 316L

Röshults Sample: ME003

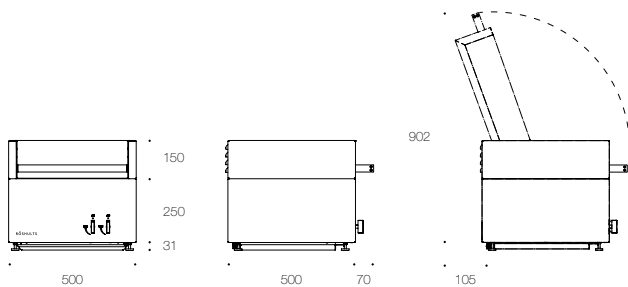

Module Gas Grill 50

Parts

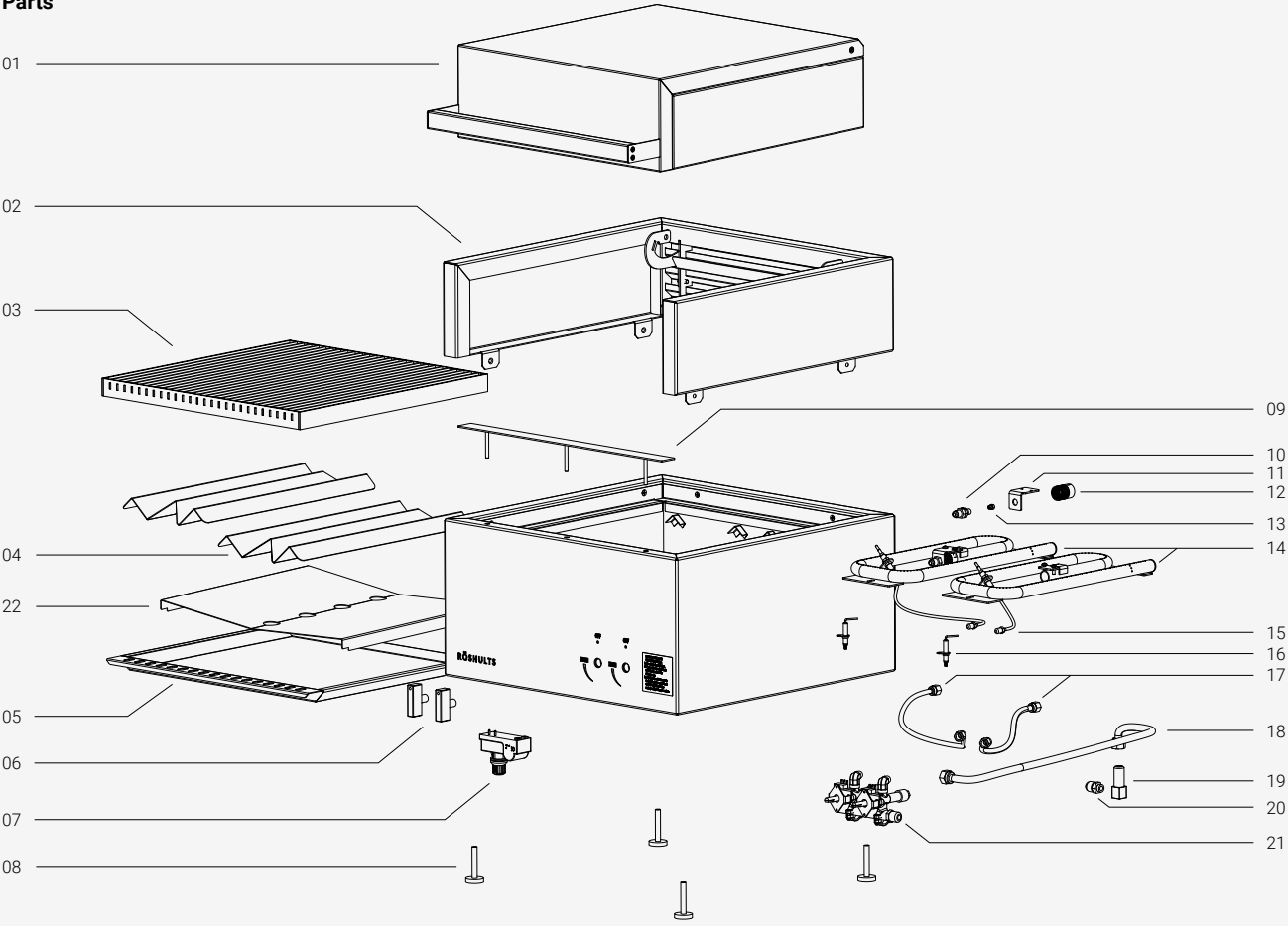

NO	DESCRIPTION	Q'TY
01	Lid	1
02	Lid base	1
03	Grill grate	1
04	Fireproof plate	1
05	Drip tray	1
06	Knob	1
07	Igniter	1
08	Feet support	4
09	Decorative plate	1
10	Injector	1
11	Nozzle console	1

NO	DESCRIPTION	Q'TY
12	Mosquito protection (some markets)	1
13	Nozzle	1
14	Burner	2
15	Thermocouple	1
16	Ignition needle	1
17	Corrugated hose 7/16"	2
18	Corrugated hose 5/8"	1
19	Gas connection angle G1/4 - 5/8-18 UNF	1
20	Gas connection G1/4 - 5/8-18 UNF	1
21	Gas valve	1
22	Drip Cover	1

Safety instructions

Please save this instruction manual for future reference. This barbecue grill is designed only for outdoor use. Don't allow young children to operate this grill.

For your safety, please note:

- Use outdoors only.
- Read the instructions before using the appliance.

Before the first use

- Accessible parts may be very hot. Keep young children away. Use protective glove when handling particularly hot components.
- This appliance must be kept away from flammable materials during use.
- Do not move the appliance during use.
- Turn off the gas supply at the gas cylinder after use.
- Do not modify the appliance.
- Don't place the gas cylinder under or near the appliance.
- The pressure regulator shall meet the European standard EN16129.
- The length of the hose shall not exceed 1.5m.
- The gas cylinder must be stored in accordance with the regulations in force.
- Only use propane and butane gas specified in the instruction manual.
- Do not use flammable liquids to light or relight your barbecue.
- Please follow the assembly instructions in this manual. Do not modify the assembly, or change any component parts. Failure to comply with these instructions may cause risk during use.
- In the event of a gas leak, immediately shut off the gas supply at the cylinder, extinguish any open flame and open the lid. Check the hoses for damage and /or poor connection. If the leak continues, immediately contact an approved gas dealer. Do not use a naked flame to check for gas leaks.
- Do not attempt to disconnect any gas fittings or connectors when the appliance is being used.
- Never leave your BBQ unattended when in use. Always cook with great care.
- This appliance should be cleaned on a regular basis. During cleaning, take care not to damage any component parts, such as the burner or valves.
- Check the flexible hoses at least once per month, and each time

you change the gas cylinder. If you find signs of cracking or deterioration, replace with a new hose of similar length and quality.

- We recommend that this appliance is serviced by an approved technician at least once per year. Do not attempt to service this appliance yourself.
- During the operation, the appliance shall be placed in a ventilation area.
- Flexible tube shall be changed every 2 years. It is necessary to change the flexible tube when the national conditions require it.
- The user shall not manipulate any parts that are sealed by manufacturer or his agent.

This appliance complies and is tested in accordance with Regulation (EU) 2016/426 - appliances burning gaseous fuels and en 498:2012

Safety practices to avoid personal injury

Keep the ventilation opening(s) of the cylinder enclosure free and clear from debris.

When properly cared for, your Röshults Grill will give safe, reliable service for many years. However, extreme care must be used since the grill produces intense heat and that can increase accident potential. When using this appliance, basic safety practices must be followed, including the following:

- Read this Care and User Manual carefully and completely before using your grill to reduce the risk of fire, burn hazard or other injury.
- Do not repair or replace any part of the grill unless specifically recommended in this manual. All other service should be referred to a qualified technician.
- **Children should not be left alone or unattended in an area where the grill is being used. Never allow them to sit, stand or play on or around the grill at any time.**
- **Do not store items of interest to children around or below the grill or in the sideboard. Never allow children to crawl inside of the grill or sideboard.**
- Never let clothing, pot holders or other flammable materials come in contact with or get too close to any grate, burner or hot surface until it has cooled. Fabric may ignite and result in personal injury.
- For personal safety, wear proper apparel. Loose fitting garments or sleeves should never be worn while using this appliance. Some synthetic fabrics are highly flammable and should not be worn while cooking.
- Only certain types of glass, heat-proof glass ceramic, earthenware, or other glazed utensils are suitable for grill use. These types of materials may break with sudden temperature

changes. Use only on low or medium heat settings according to the manufacturer's directions.

- Do not heat unopened food containers as a build-up of pressure may cause the container to burst.
- Use a covered hand when opening the grill lid. Never lean over an open grill.
- **When lighting the burner, always pay close attention to what you are doing. Be certain you are turning the igniter labeled for the burner you intend on using.**
- **Do not operate burners on high with lid closed.**

Before you start the gas grill

Before you use the grill for the first time, the drip tray should be filled with a 10 mm thick layer of grease-absorbing, non-combustible material, for example fine-grained sand. This material is used to soak up the grease and oils that could cause the grease/oil to ignite. A useful tip is to place aluminum foil in the drip tray to make handling the sand (or other material) easier. We recommend that you wash the grill grates before using them for the first time.

List of conversion kits:

NO	DESCRIPTION	Q'TY
01	Burner Injector Size Nozzle ϕ 0.96	2 (Assembled on BBQ)
02	Burner Injector Size Nozzle ϕ 0.88	2
03	Burner Injector Size Nozzle ϕ 0.91	2
04	Burner Injector Size Nozzle ϕ 1.52	2
05	Gas connection copling SE	1 (Assembled on BBQ)
06	Gas connection copling DE	1
07	Gas connection copling UK	1
08	Gas connection copling FR	1

Each conversion kit shall be accompanied by clear, concise printed instructions and diagrams. Terms should be stated clearly and understandable, adequate for the proper field assembly, installation, service, and safe use of the conversion kit.

⚠ Warning!

Fire, explosion, and carbon-monoxide hazard. If the information in these instructions is not followed exactly, a fire, explosion, or production of carbon monoxide may result causing property damage, personal injury, or loss of life.

This conversion kit shall be installed by a qualified service agency in accordance with the manufacturer's instructions and all applicable codes and requirements of the authority having jurisdiction. If the information in these instructions is not followed exactly, a fire, explosion or production of carbon monoxide may result causing property damage, personal injury or loss of life. The qualified service agency is responsible for the proper installation of this kit. The installation is not proper and complete until the operation of the converted appliance is checked as specified in the manufacturer's instructions supplied with the kit.

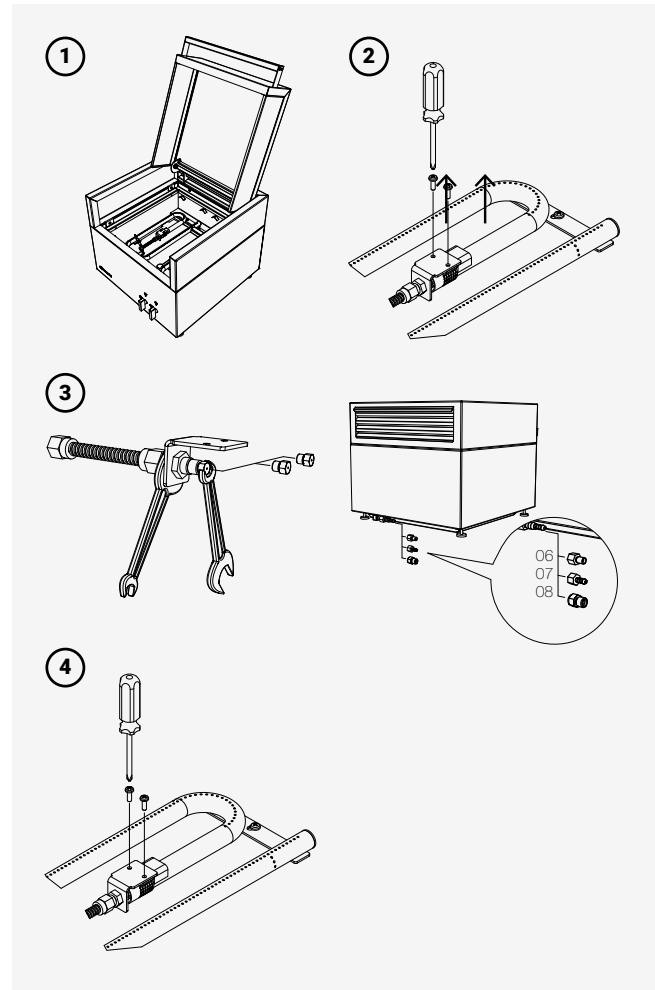

Changing nozzle and gas coupling

1. Open lid and remove cooking grills and fireproof plate. Set aside for later use
2. Change Nozzle according to technical data specification sheet above and instruction in the following pictures.
3. Select and connect the gas connection suitable for your country regulation.
4. Attach the screws again.

LEAK TESTING

General

Although all gas connections on the grill are leak tested at the factory prior to shipment, a complete gas tightness check must be performed at the installation site due to possible mishandling in shipment, or excessive pressure unknowingly being applied to the unit.

Periodically check the whole system for leaks following the procedures listed below. If the smell of gas is detected at anytime you should immediately check the entire system for leaks.

Make sure that all packing material is removed from the grill including the burner tie-down straps. All burners in your new Röshults grill have been fire tested at the factory. You may notice a slight discoloration due to the factory fire testing.

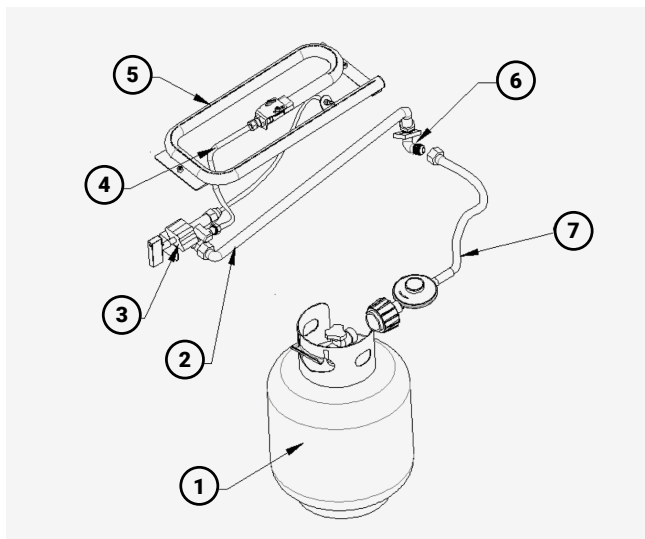

Do not smoke while leak testing. Never leak test with an open flame. Make a soap solution of one part liquid detergent and one part water. You will need a spray bottle, brush, or rag to apply the solution to the fittings. For the initial leak test, make sure the L.P. cylinder is full.

To test

Make sure all control valves are in the "OFF" position. Turn the gas supply on. Check all connections from the L.P. cylinder up to and including the connection to the manifold pipe assembly (the pipe that goes to the burners).

Apply a soapy water mixture to the following (see numbers 1-7):

1. Cylinder.
2. The inlet end of the corrugated pipe is connected to the gas valve, and the other end is connected with L type connector.
3. Gas valve.

4. The corrugated pipe outlet is connected gas valve.
5. The corrugated pipe outlet are aligned to the burner hole.
6. L type connector.
7. The reducing valve is connected to L type connector and other end is connected the gas cylinder (clockwise).

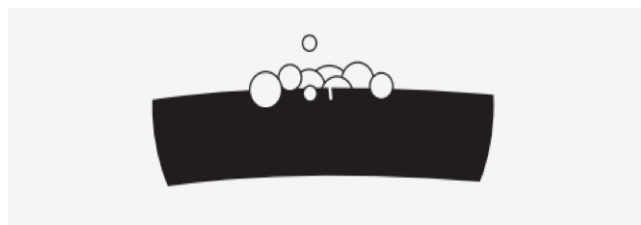

Soap bubbles will appear where a leak is present. If a leak is present, immediately turn off the gas supply, tighten any leaking fittings, turn gas on, and recheck.

Should the gas continue to leak from any or all of the fittings, turn off the gas supply, and contact our customer service at +46 36 440 32 10.

Only those parts recommended by the manufacturer should be used on the grill. Substitution will void the warranty. Do not use the grill until all connections have been checked and do not leak.

Gas flow check:

Each grill burner is tested and adjusted at the factory prior to shipment; however, variations in the local gas supply may make it necessary to adjust the burners. The flames of the burners should be visually checked.

Flames should be blue and stable with no yellow tips, excessive noise or lifting. If any of these conditions exist, check to see if the

Secure that your gas grill is adapted for the intended use of gas and gas connection as specified in the technical data below:

Module Gas Grill 50						
Manufacturer name address	Röshults Svenska Hantverk AB Kärriolsvägen 7, 554 75 Jönköping, Sweden					
Gas Category	I3 + (28-30/37)	I3B/P(30)	I3B/P(50)	I3B/P(37)	I2H	I2E
Gas and Supply Pressure	G30 Butane at 28-30 mbar G31 Propane at 37 mbar	G30 Butane and G31 Propane at 30mbar	G30 Butane and G31 Propane at 50mbar	G30 Butane and G31 Propane at 37mbar	Methane G20 20mbar	Methane G20 20mbar
Country Code	BE, CH, CY, CZ, ES, FR, GB, GR, IE, IT, LT, LU, LV, PT, SK, SI	BE, CY, DK, EE, FR, GB, HU, IT, LT, NL, NO, SE, SI, SK, RO, HR, TR, BG, IS, LU, MT, FI	AT, CH, DE, SK	PL	AT, CH, CZ, DK, EE, ES, FI, FR, GB, GR, HU, IE, IT, LT, LV, NL, NO, PT, RO, SE, SI, SK	DE, LU, PL, RO
Burner	2	2	2	2	2	2
Nominal Heat Input (single burner)	4kW	4kW	4kW	4kW	4kW	4kW
Burner Injector Size	0.96mm	0.96mm	0.88mm	0.91mm	1.52mm	1.52mm
Total Heat Input	8kW (G30:582g/h;G31:572g/h) (G20:0.76m3/h)					
Service center	Röshults Svenska Hantverk AB					

air shutter or burner ports are blocked by dirt, debris, spider webs, etc. If you have any questions regarding flame stability, please call customer service +46 36 440 32 10.

Preparation

You need a gas cylinder and a proper regulator to reach the gas pressure to operate this gas grill. Regulator should comply with current version and national regulation.

Installation

After purchasing your gas cylinder you will then be ready to set it up with your gas grill. The recommended weight of the cylinders are 5-11kg. Check all the parts, and make sure no part is missing. If there are any parts missing, please contact customer service. The distance between the appliance and the wall is as follows for reference.

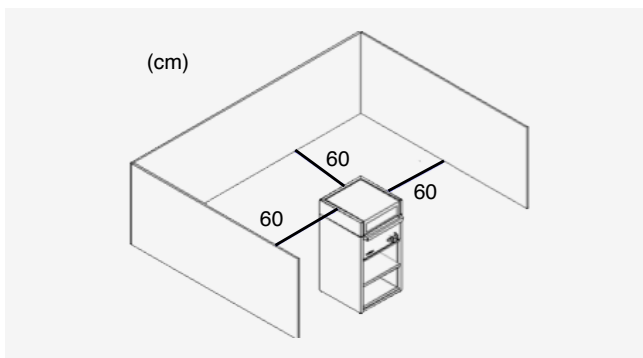

Operations

1. When changing the gas cylinder which shall be carried out away from any source of ignition. Position the gas cylinder at any side of your gas grill, should not be placed inside or under the grill, keeping in mind that the gas cylinder must be kept away from heat and in a safe position.

Important! Always follow instructions provided by the gas cylinder supplier. Also follow the regulations valid for your country.

2. Identify which type of regulator you need and follow the instructions provided by the gas hose supplier. Also follow the regulations valid for your country.
3. When ready to use your gas grill insert the regulator into the gas cylinder valve and tighten firmly.

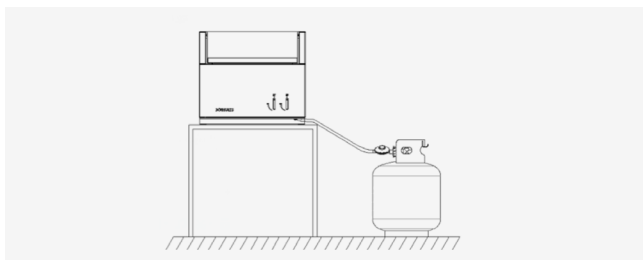

Warning!

Before attempting to light your gas grill you must refer to your lighting instructions and warning / safety precautions.

Check the hose before each use, searching for cracking, cuts or

any abrasions. If the hose is found to be faulty in any way do not attempt to use your gas grill. When changing your gas cylinder ensures that there are no sources of ignition close by fires, cigarettes, naked flames etc. Make sure that the appliance is switched off. The appliance only can use liquid gas cylinder as per Technical Data Label. The gas cylinder should meet the national requirement.

Safety precautions

- Always test gas line for leaks at connector with soapy water after making connections.
- The top lid must always be open when lighting the burner.
- Use oven gloves and sturdy long handled gas grill tools when cooking on the grill.
- Be prepared if an accident or fire should occur. Know where the first aid kit and fire extinguishers are and know how to use them.
- Keep any electrical supply cord and the fuel supply hose away from any heated surfaces.
- Always cook with great care.
- Do not heat any unopened glass or metal container of food on the grill. Pressure may build up and cause the container to burst, possibly resulting in serious personal injury or damage to the grill. It is recommended to use protective gloves when operating the appliance, especially handling particularly hot components.

Igniting the Grill

Burner: Each gas consumption (per hour) of the BBQ Grill Gas Module X with all burners on "HIGH":

Main Burner	4KW
Total	8KW

Prior to lighting the burners, all checks and procedures detailed in the chapter 'Before the first use' must have been carried out.

- The lid of the appliance must always be open when you light the burner(s).
- Do not bend directly over the appliance when lighting the burner(s).
- The control knobs of the appliance must be 'OFF'. Slowly open the gas cylinder valve. Before opening the control knob of one burner, wait approx. 10 seconds to allow to gas to stabilize.
- As soon as one burner has been lighted, you only need to put the control knob of the other burner(s) in the position to light them.
- Never try to light all burners at once.

Lighting procedure

1. Open lid during lighting
2. Push and turn the control knob to "HIGH" and hold for 3-5 sec.

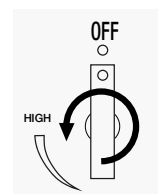

- If ignition does NOT occur in 5 seconds, turn control knob to "OFF", wait 5 minutes and repeat lighting procedure.

Lighting using match light extension rod

If the burner will not light after several attempts then the burner can be match lit.

Extension rod is placed in the driptray in the front of the BBQ:

- Keep lid open through whole process.
- Turn OFF all burner valves.
- Place a lighted match between the coils on the extension rod and hold next to the burner.
- Turn the control knob to the "HIGH" position and press knob. Burner should light immediately.
- If the burner does not light in 4 seconds turn the knob off, wait 5 minutes with lid open and repeat above procedures.

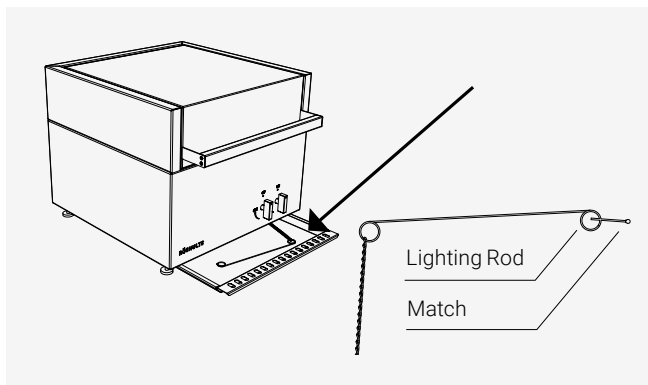

⚠ Danger!

Keep your face and hands as far away from the grill as possible when lighting it.

Flame Characteristics

This procedure outlines how to check for the proper burner flame characteristics. Check for proper burner flame characteristics. Each burner is adjusted prior to shipment; however, variations in the local gas supply may take minor adjustments necessary.

Burner flames should be blue and stable with no yellow tips, excessive noise, or lifting. If any of these conditions exist call our customer service line. If the flame is yellow, it indicates insufficient air. If the flame is noisy and tends to lift away from the burner, it indicates too much air.

Visually check the burner flames prior to each use. The flame should look like this picture. If they do not, refer to the burner maintenance part of this manual.



Natural Gas Change Connected Instructions

Each conversion kit shall be accompanied by clear, concise printed instructions and diagrams, stated in terms clearly understandable, adequate for the proper field assembly, installation, service, and safe use of the conversion kit.

⚠ Warning!

Fire, Explosion, and Carbon-Monoxide Hazard

If the information in these instructions is not followed exactly, a fire, explosion, or production of carbon monoxide may result causing property damage, personal injury, or loss of life.

This conversion kit shall be installed by a qualified service agency in accordance with the manufacturer's instructions and all applicable codes and requirements of the authority having jurisdiction. If the information in these instructions is not followed exactly, a fire, explosion or production of carbon monoxide may result causing property damage, personal injury or loss of life. The qualified service agency is responsible for the proper installation of this kit. The installation is not proper and complete until the operation of the converted appliance is checked as specified in the manufacturer's instructions supplied with the kit.

Please stick the conversion label after change to Natural gas, that have ready in conversion kit. The position is nearby main label.

Please re-do the leak testing and try to light the grill after change to Natural gas immediately.

Natural Gas Conversion kit consists of a $\phi 1.52$ mm nozzle, and a conversion label.

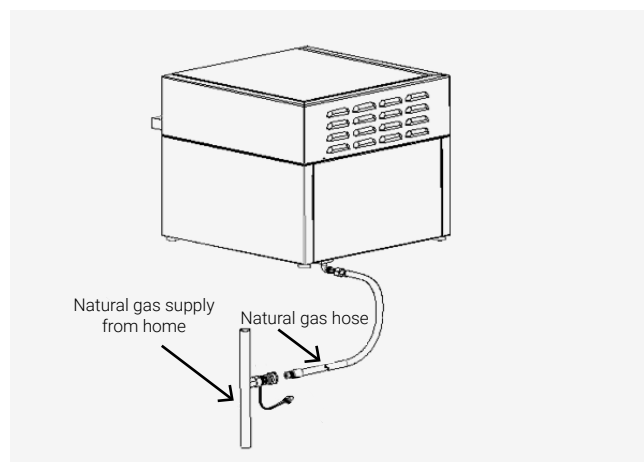

NO	DESCRIPTION	Q'TY
01	$\phi 1.52$ mm Nozzle	2

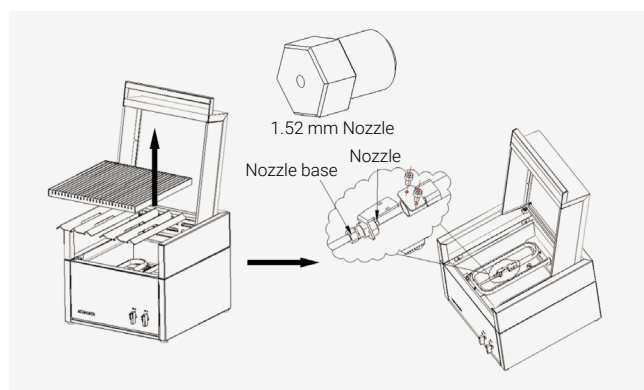

1.52 mm Nozzle

- Open lid and remove cooking grills and fireproof plate. Set aside for later use.

- Use the $\phi 1.52$ mm NG Nozzle to change it. Lock back the nozzle into burner with screws and check that the nozzle is aligned with the burner.

**THE INSTALLATION OF THE APPLIANCE
MUST BE ACCORDING TO THE NATIONAL LAW.**

Care & Maintenance

Storage

Your gas cylinder must be stored outdoors in a well ventilated area and must be disconnected from your gas grill when not in use. Ensure that you are outdoors and away from any sources of ignition before attempting to disconnect your gas cylinder from your gas grill. When you are using your gas grill after a period of storage, please ensure to check for gas leaks and check for any obstructions in the burner etc. before using. Always follow the cleaning instructions to ensure gas grill is safe. If gas grill is stored outdoors ensure to check that all areas under the front panel are free from any obstructions (dirt, insects etc.) as this may affect the flow of gas.

- Store your barbecue in a cool dry place. It may be necessary to dry the barbecue and the inside of the cover if used.
- Clean the grill grate by using a brush or ruff sponge, soap and luck warm water. Wrap the burners in aluminum foil to help prevent insects or other debris from obstructing the burners.

Maintenance

- Maintenance is recommended every 90 days for your gas grill, but it is absolutely necessary to perform maintenance at least once a year. By doing so, you will extend the life of your gas grill. Your gas grill is easy to clean with minimum effort, just follow these helpful hints for cleaning convenience.

Stainless steel

- The grill is made from stainless steel. Some parts of the frame, depending on the model, can be powder coated on top of stainless steel material.
- The easiest way to keep your BBQ in a good condition we recommend cleaning the grill after each use.
- Use lukewarm water, soap and a sponge. Always scrub in the direction of the grain.

Outside/frame of the grill

- Wipe down the outside of the grill to ensure that there is no residual marinade or fat/grease that could corrode the surface. Use soap and water to remove any stubborn residues.
- For cleaning powder coated surface, use a cloth or a soft sponge.

Regular Checks & Maintenance

Gas cylinder

- Ask your local dealer/retailer to check the gas cylinder each time you change it or fill it with gas.

Hose and regulator

- Rubber has a limited useful life and becomes worn over time. If there is any damage or cracks, replace the hose immediately.
- Check the rubber gasket on the connection that is screwed into the gas cylinder to ensure that it is not cracked or dried out.

Burners

- Turn the knob to maximum and burn off any fat and grease for five minutes after cooking.
- Clean the burners as described above after each barbecue - residual marinades and fat/grease can cause damage to the metal parts of the grill.
- The burner holes can be cleaned with a pipe cleaner or similar.

Stainless grill grates

- The easiest way to clean the grill is immediately after cooking is completed and after turning off the flame. Wear a barbecue mitt to protect your hand from the heat and steam. Dip a stainless steel barbecue brush in tap water and scrub the hot grill. Dip the brush frequently in the bowl of water. Steam, created as water contacts the hot grill, assists the cleaning process by softening any food particles. The food particles will fall and burn. If the grill is allowed to cool before cleaning, cleaning will be more difficult.
- It is also possible to keep the grill grates clean by turning the burner knob to maximum and burning off fat and grease for five minutes after cooking. Use a grill grate brush or similar to remove any particularly stubborn dirt.

- **Please note! Do not use solvents!**

Stainless Drip Cover in bottom of the grill frame

How to clean and remove the bottom plate:

1. Remove the grill grate and fire proof plate.

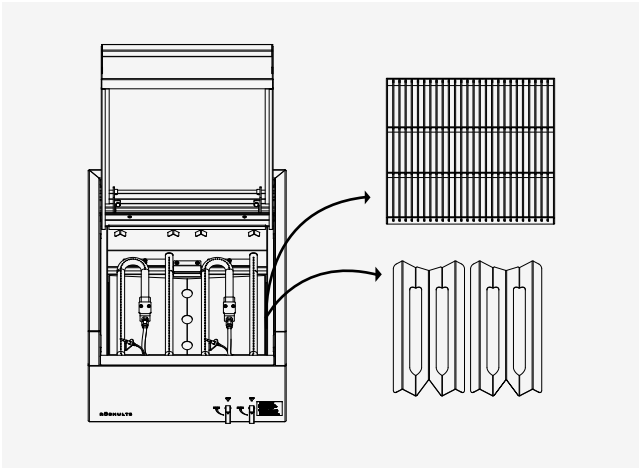

2. Pull out the drip tray.

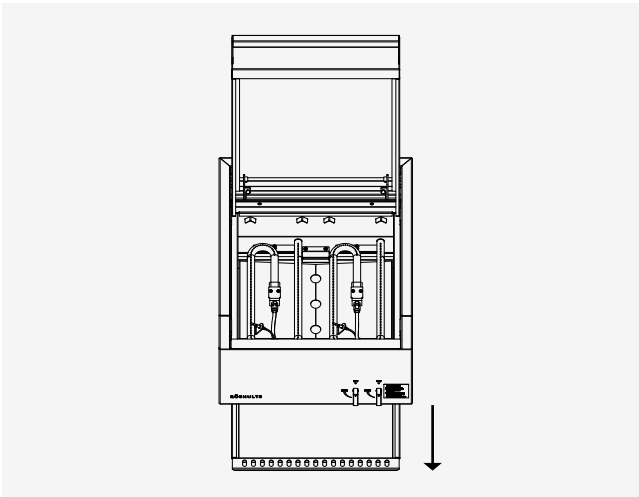

3. Lift the bottom drip cover by putting a finger through the hole closest to the back of the grill and lift upwards and then pull outwards.

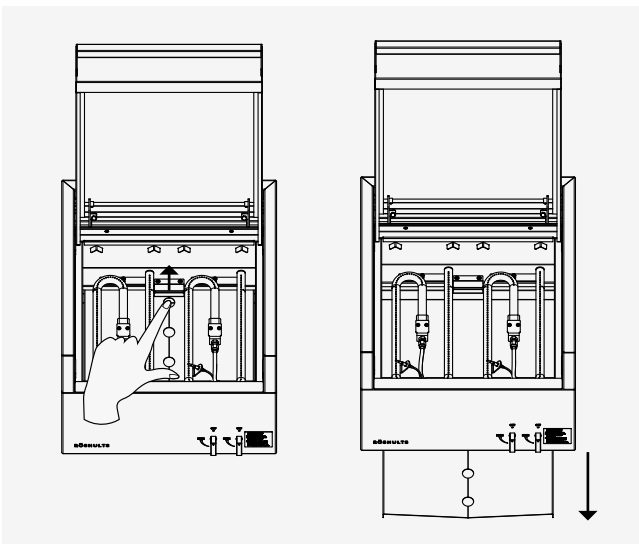

Reassemble the grill in reverse order to the way you disassembled.

Grill part

- Use a plastic or wooden scraper to scrape away grease/fat from the inside of the grill. Soapy water and a sponge is recommended for more thorough cleaning. It is important to ensure that the regulator and valves do not become wet.
- It is important to keep the inside of the grill clean - otherwise there is a risk that residual fat and grease will ignite.

Drip tray

- Check the sand in the drip tray regularly to ensure that it is dry and clean. Change the sand as required (use fine-grain sand or cat litter box sand)

Changing the battery

The barbecue is equipped with electrical ignition and is powered with an AA battery. After a while, the battery needs to be changed. The battery holder is placed on in the front on the left side under the grill. You change the battery by twisting the lower section of the battery holder counter-clockwise. Remove the old battery and replace it with a new one. Remount the battery holder and check that it works.

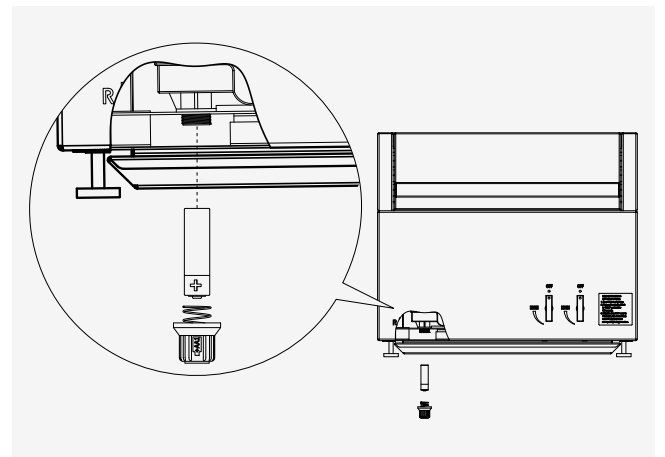

Troubleshooting

Spider and insect warning!

Spiders and insects can nest in the burners of this or any other grill, and cause the gas to flow from the front of the burner. This is a very dangerous condition which can cause a fire to occur behind the valve panel, thereby damaging the grill and making it unsafe to operate.

When to look for spiders

You should inspect the burners at least once a year or immediately after any of the following conditions occur:

- The smell of gas in conjunction with the burner flames appearing yellow.
- The grill does not reach temperature.
- The grill heats unevenly.
- The burners make popping noises.

Before calling for service

If the grill does not function properly, use the following checklist before contacting your dealer for service.

FAQ

Q: What is the function of the plates that rest above the burners?

A: These plates, or flame fenders as they are also known, provide protection against flames that flare up towards the food on the grill grates. The plates significantly increase the useful life of the burners by protecting them against oil, fat, grease and juices from the food. The plates also provide a very even distribution of heat at the grill grates.

Q: How long do I need to wait before I can start cooking food on the grill?

A: It normally takes 5-10 minutes for the grill to reach the right temperature.

Q. Can I use lava stones in the grill?

A: No, lava stones should not be used with Röshults' grills.

Problems

Grill won't light when the control knob is rotated.

- Check to see if LP tank is empty.
- Clean wire(s) and/or electrode by rubbing with alcohol and clean swab.
- Wipe with dry cloth.
- Make sure the wire is connected to electrode assembly.
- Do other burners on the unit operate?
- Check to see if other burners operate. If so, check the gas orifice on the malfunctioning burner for an obstruction.

Burner flame is yellow or orange, in conjunction with the odor of gas.

- Call our customer service line +46 36 440 32 10..

Low heat with knob in "HIGH" Position.

- Is the fuel hose bent or kinked?
- Is the grill in a dusty area?
- Is there adequate gas supply available?
- If it is only one burner that appears low, does the orifice or burner need cleaning?
- Is the gas supply, or gas pressure low?
- Is the grill being preheated for 15 minutes?

Warranty

Model: Module Gas Grill 50
Stainless Steel Outdoor Gas Grill

Röshults warrants to the original consumer purchaser of each Outdoor Gas Grill that when subject to normal residential use, it is free from defects in workmanship and materials for the periods specified below. This warranty excludes grills used in rental or commercial applications. There will be a shipping and handling charge for the delivery of the warranty part(s).

COMPONENT	WARRANTY PERIOD
Burners	5 years
Stainless Steel Flame Tamer	3 years
Stainless Steel Cooking Grids	3 years
Valves	1 year
Frame, Housing, Cart, Control Panel, Igniter, and Related Parts	1 year
All Stainless Steel Parts	3 years

Our obligation under this warranty is limited to repair or replacement, at our option, of the product during the warranty period. The extent of any liability of Röshults under this warranty is limited to repair or replacement.

This warranty does not cover normal wear of parts, damage resulting from any of the following:

- Negligent use or misuse of the product.
- Use on improper fuel/gas supply.
- Use contrary to operating instructions.
- Alteration by any person other than our factory service center.

The warranty period is not extended by such repair or replacement.

Warranty claim procedure

If you require service or parts for your grill, please contact our Warranty Service Center for factory direct assistance. Our hours of operation are 8 AM to 5 PM CET.

Our phone number: +46 36 440 32 10

Our email: info@roshults.com

Please direct all correspondence to your local dealer.

Product repair as provided under this warranty is your exclusive remedy. Röshults shall not be liable for any incidental or consequential damages for breach of any express or implied warranty on its products. Except to the extent prohibited by applicable law, any implied warranty or merchantability or fitness for a particular purpose on this product to the duration of the above warranty. Some states do not allow the exclusion or limitation of incidental or consequential damages, or allow limitations on how long an implied warranty lasts, so the above limitations or exclusions may not apply to you. This warranty gives you specific legal rights, and you may have other rights, which vary from state to state.

